

TECHNICAL DATA	
Model	From 50 to 2500 mm
Measurement taken	Displacement / Speed
Position read sampling time (typical)	From 0,5 ms to 3 ms (depending on stroke)
Speed measurement range	min 0 .. 0,1 m/s max 0 .. 10 m/s
Accuracy speed	< 2% (in all F.S.)
Shock test DIN IEC68T2-27	100g - 11ms - single shock
Vibrations DIN IEC68T2-6	12g / 10...2000Hz
Displacement speed	≤10 m/s
Max. acceleration	≤ 100 m/s ² displacement
Resolution	16 bit (max electrical noise 5 mVpp)
Cursor (see note)	Sliding cursor Floating separate cursor
Working temperature	-30...+75°C
Storage temperature	-40...+100°C
Coefficient of temperature	0.005% F.S. / °C
Protection	IP67

Note: 1) For strokes > 2500 mt use sliding or floating cursors with max. distance of 4mm
2) For multi-cursor versions, the cursors have to work under the same distance and temperature conditions

ELECTRICAL DATA		
Output signal	0...10V (N/P/Y)	4...20mA (E/F/H) 0...20mA (B/C/D)
Nominal power supply	24 Vdc ±20%	24 Vdc ±20%
Max. power ripple	1Vpp	1Vpp
Max. consumption	70mA	90mA
Max. output load	5kΩ	< 500Ω
Max. output noise	< 5mVpp	< 5mVpp
Max. output value	12V	30mA
Alarm output value	10.5V	21mA
Electrical isolation	500V (*)	500V (*)
Protection against polarity inversion	Yes	Yes
Protection against overvoltage	Yes	Yes
Protection against power supply in output	Yes	Yes

(*) It includes a 30V 0,4J voltage suppressor

Main characteristics

- Optimised mechanical structure
- Strokes from 50 to 2500 mm
- Sliding or floating magnetic cursor
- Availability of several analogue outputs (voltage or current) for direct position and speed measurement or reverse measurement (only position)
- Single or double cursors models availability
- Power supply 24Vdc ±20%
- Resistance to vibration (DIN IEC68T2/6 12g)
- IP67 protection
- Work temperature: -30...+75°C
- Electromagnetic compatibility EMC 2014/30/EU
- Compliant to the directive RoHS 2011/65/EU

Contactless linear position transducer with HYPERWAVE magnetostrictive technology.

The absence of electrical contact on the cursor eliminates all wear and guarantees almost unlimited life. High performance in terms of environmental IP protection and EMC immunity. High accuracy of the measurement with reference to the non linearity, repeatability and hysteresis. High resistance to vibrations, mechanical shocks for use in a harsh industrial environment.

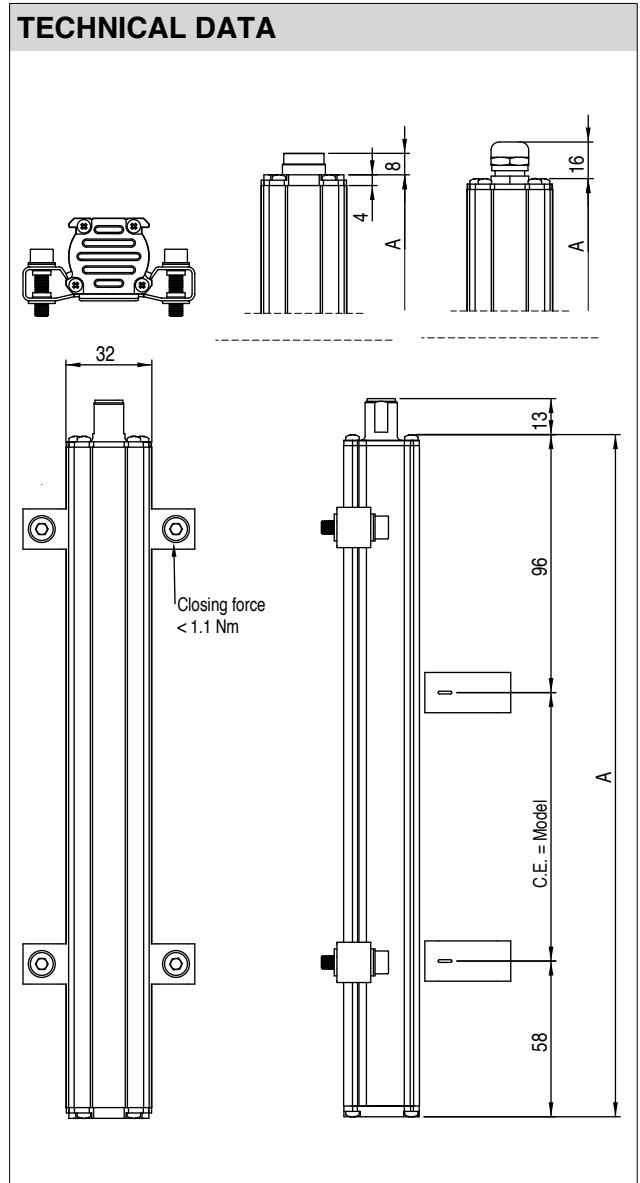

ELECTRICAL / MECHANICAL DATA																					
Model	50	75	100	130	150	350	360	400	450	500	550	600	650	1200	1250	1300	1400	2250	2500		
	175	200	225	250	300	700	750	800	850	900	950	1000	1100	1500	1750	2000					
Sampling time	ms	0,5				1						1,5			2						
Electrical stroke	mm	Model																			
Independent linearity	± %/FS	Typical: $\leq \pm 0,02$ % FS (min $\pm 0,060$ mm) with sliding cursor max: $\leq \pm 0,02$ % FS with floating cursor at a distance between 2 and 5 mm max: $\leq \pm 0,04$ % FS with floating cursor at a distance between 5 and 7 mm																			
Max.dimensions (A)	mm	Model + 154																			
Repeatability	mm	<0,01 (limited by the resolution of the output value)																			
Hysteresis	mm	<0,01 (limited by the resolution of the output value)																			

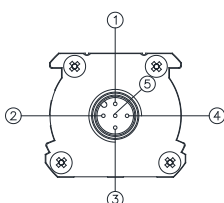
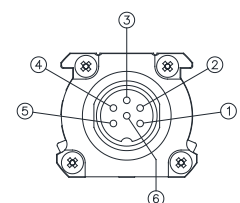
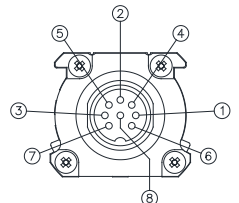
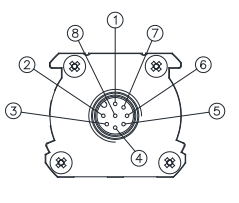
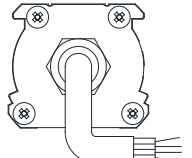
ELECTRICAL CONNECTIONS				
OUTPUT WPP-A-A	OUTPUT WPP-A-B	OUTPUT WPP-A-C	OUTPUT WPP-A-H	OUTPUT WPP-A-F
				

Function	CONNECTORS				CABLES	OPTIONAL CABLES FOR	
	WPP-A-A	WPP-A-B	WPP-A-C	WPP-A-H	WPP-A-F	WPP-A-A	WPP-A-H
	5 pin M12	6 pin M16	8 pin M16	8 pin M12	Standard cable	Pre-assembled 5 pin	Pre-assembled 8 pin
Output cursor 1 0...10V 4...20mA 0...20mA	1	1	5 (1*)	5	Grey	Brown	Green
GND Output cursor 1 (0V)	2	2	2	1	Pink	White	Yellow
Inverse output cursor 1 Output cursor 2 Output speed 0...10V 4...20mA 0...20mA	3	3	3	3	Yellow	Blue	Pink
GND Output cursor 1 Output cursor 2 Output speed (0V)	2	4	6	2	Pink	White	Grey
Power supply+	5	5	7	7	Brown	Grey	Brown
Power supply GND	4	6	8	6	White	Black	Blue
n.c.	-	-	4	4	-	-	Red
n.c.	-	-	1(5*)	8	-	-	White

(*) = for version 4...20mA / 0...20mA

The transducer case must be grounded with the cable sheathing on the control system side only.

ANALOG OUTPUT

The WPP-A magnetostrictive transducers provide a direct and reverse voltage or current analogue output proportional to the magnetic cursor's position. Since the output is direct, no signal electronic processing is required if interfaced with controllers or measurement instruments.

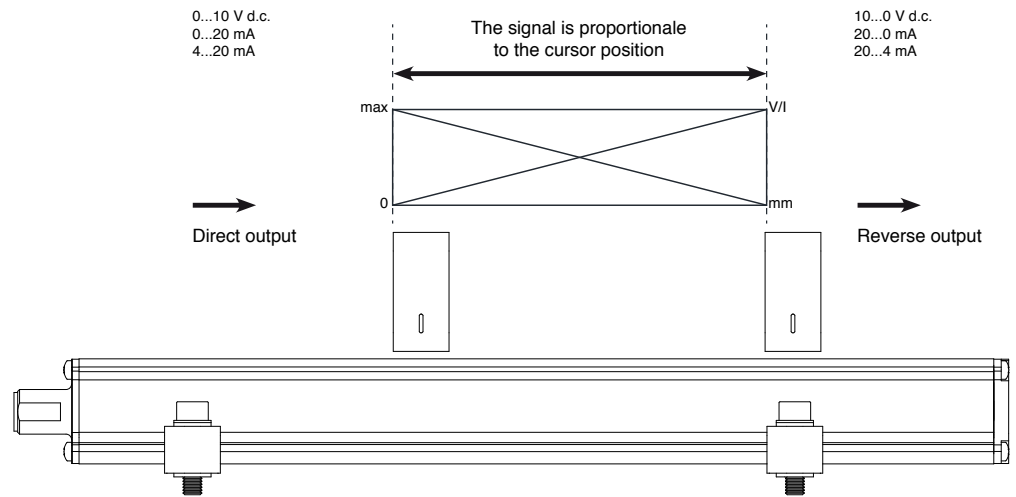

ORDER CODE

Position transducer

W P P A [] [] [] [] [] [] [] []

Analog output **A**

Connector

M12 5-pin connector output **A**

Available on request

DIN45322 6-pin connector output **B**

DIN45326 8-pin connector output **C**

M12 8-pin connector output **H**

PVC cable output **F**

Model

Output

0...10Vdc	1 cursor	N
0...10Vdc	1 cursor, position and speed	P
0...10Vdc	2 cursors (min. stroke 360mm)	Y
4...20mA	1 cursor	E
4...20mA	1 cursor, position and speed	F
4...20mA	2 cursors (min. stroke 360mm)	H
<i>Available on request</i>		
0...20mA	1 cursor	B
0...20mA	1 cursor, position and speed	C
0...20mA	2 cursors (min. stroke 360mm)	D
0...+5Vdc	1 cursor	K

0 0 0 0 X 0 0 0 X 0 0 X 0 X X

Output of speed

Only for analogic output option C, F, P

Maximum measurable speed:
0.1...10.0 m/s

00.0 Function not required

00	A, B, C, H Outputs
<i>Output F cable length</i>	
00	1 m
05	5 m
10	10 m
15	15 m

Mechanical and/or electrical characteristics differing from those in the standard version may be arranged on request.

Es.: WPP-A-B-0400-N, PKIT090, PCUR210

Transducer model WPP, analog output, 6-pin connector, model 400, 0...10Vdc output, PKIT090 brackets, PCUR210 standard cursor.

CURSORS ON REQUEST

PCUR202



Floating Cursor

PCUR210

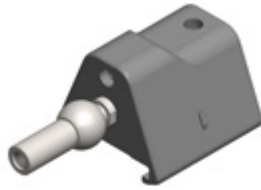

Sliding cursor,
axial joint low

PCUR211

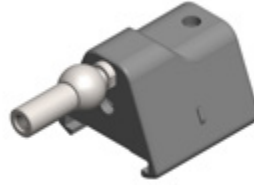

Sliding cursor,
axial joint high

PCUR212



Sliding cursor,
axial joint angle

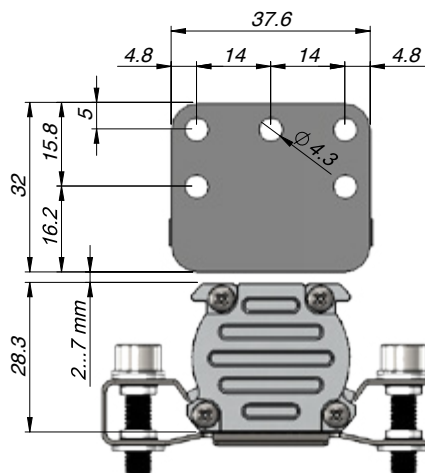
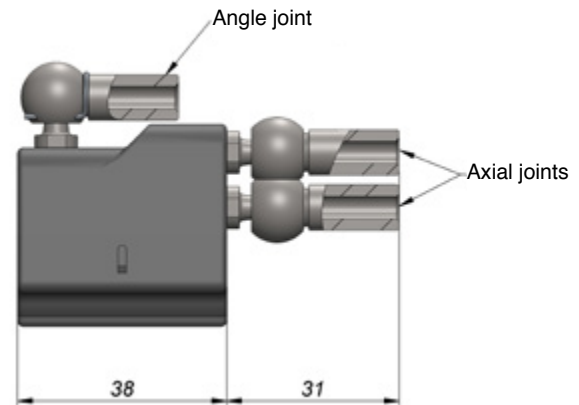
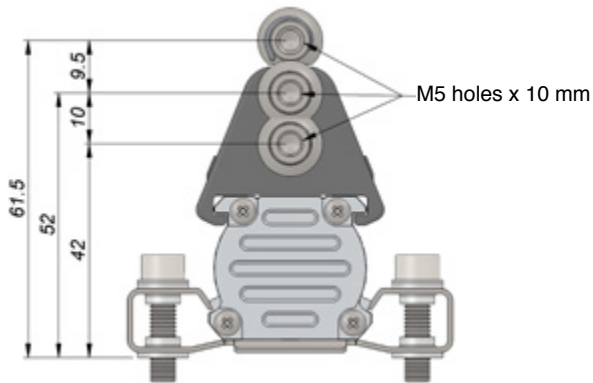

BRACKETS ON REQUEST



Brackets (2 brackets for every kit)	
Steel brackets, interaxis 42.5mm	090
Steel brackets, interaxis 50mm	091

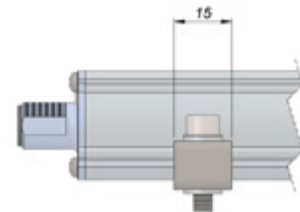

Brackets code	Interaxis (i)	Screw (V)	Dimension (A)
PKIT090	42.5	M4	56
PKIT091	50	M5	63.5

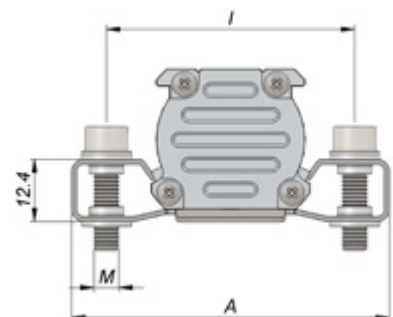

OPTIONAL FEMALE CONNECTORS

For A-H outputs, M12 thread connector

Code: **CON031** for 5-pin output (WPP-A-A)
CON041 for 5-pin output (WPP-A-A)
CON035 for 8-pin output (WPP-A-H)
CON042 for 8-pin output (WPP-A-H)

For B-C outputs, M16 thread connector

Code: **CON021** for 6-pin output (WPP-A-B)
CON022 for 6-pin output (WPP-A-B)
CON023 for 6-pin output (WPP-A-B)
CON026 for 8-pin output (WPP-A-C)
CON027 for 8-pin output (WPP-A-C)
CON028 for 8-pin output (WPP-A-C)

Connector extraction length: 10mm

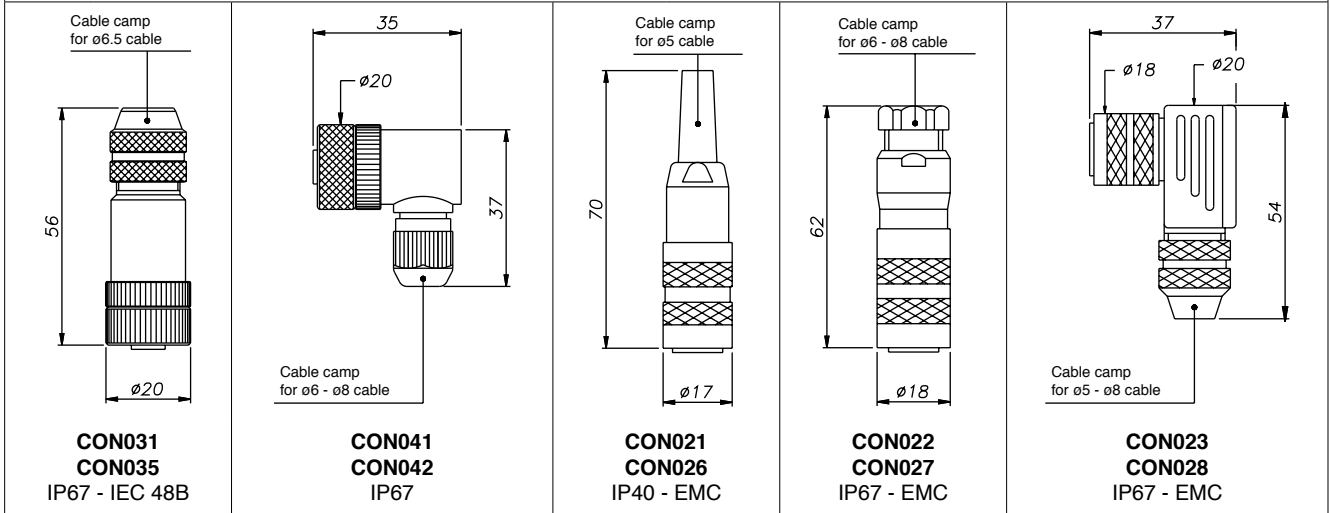

OPTIONAL CABLES OUTPUT

PRE-ASSEMBLED CABLE WITH STRAIGHT CONNECTOR

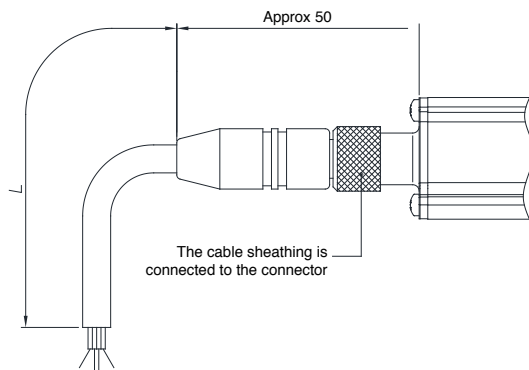

5-pin cable code		WPP-A-A	
Length "L"		CODE	
		Straight cable	Cable to 90°
2	mt	CAV011	CAV021
5	mt	CAV012	CAV022
10	mt	CAV013	CAV023
15	mt	CAV015	CAV024

PRE-ASSEMBLED CABLE WITH 90° CONNECTOR

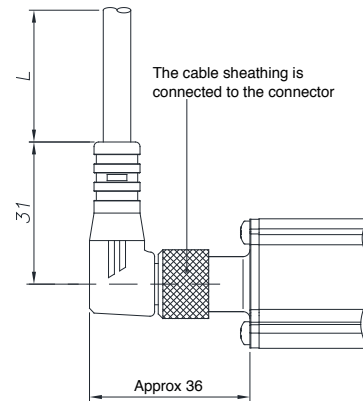

8-pin cable code		WPP-A-H	
Length "L"		CODE	
		Straight cable	Cable to 90°
2	mt	CAV002	CAV005
5	mt	CAV003	CAV006
10	mt	CAV004	CAV007
15	mt	CAV009	CAV008

GEFRAN spa reserves the right to make aesthetic or functional changes at any time and without notice